

HSGM-Styro-Cut 230

Description:

The professional tool for the building trade, industry and design. With electronic power regulator, for optimum adjustment of the cutting temperature.

With it, you can cut polystyrene sheets up to a thickness of 230 mm without any problems.

You can also use our profile cutters to insert various profiles into polystyrene sheets.

Hot cutting of Styrofoam avoids dust and static charge.

Technical data:

Supply voltage: 230 V - 50 Hz
 Power input: max. 230 W
 Operation time: Intermittent operation 1/4min.
 Protection class: II – Protective insulation
 Power supply: Supply cord 3 m, with European-type plug
 Weight: 0,6 kg Device
 1,5 kg Device with accessories



HSGM-Styro-Cut 230 with cutting blade DSS-220

Lieferumfang:

1x HSGM-Styro-Cut 230
 1x Cutting blade DSS-220, for 200mm boards
 1x Cutting blade DSS-250, for 230mm boards
 1x Brass brush
 1x Screwdriver
 1x Plastic case
 1x Operating instructions with Declaration of Conformity

Mögliche Schneiden:

<p>Typ DSS-200 For 180mm boards</p> <p>Item-No.:2700700557</p>	<p>Typ DSS-220 For 200mm boards</p> <p>Item-No.:2700700558</p>	<p>Typ DSS-250 For 230mm boards</p> <p>Item-No.:2700700562</p>	<p>Typ CN-100 For 100mm boards</p> <p>Item-No.:2700700521</p>
<p>Typ C-140 For 140mm boards</p> <p>Item-No.:2700700522</p>	<p>Typ C-180 For 180mm boards</p> <p>Item-No.:2700700526</p>	<p>Typ C-200 For 200mm boards</p> <p>Item-No.:2700700530</p>	<p>Typ C-230 For 230mm boards</p> <p>Item-No.:2700700536</p>
<p>Typ D68-61 Cutting blade for holes with D=68mm for spar wall boxes</p> <p>Item-No.:2700700540</p>	<p>Typ CN-14 Half-round, Slot width 14mm</p> <p>Item-No.:2700700564</p>	<p>Typ CN-20 Half-round, Slot width 20mm</p> <p>Item-No.:2700700566</p>	<p>Typ CN-26 Half-round, Slot width 26mm</p> <p>Item-No.:2700700568</p>

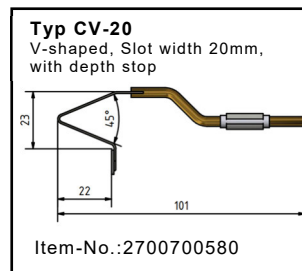
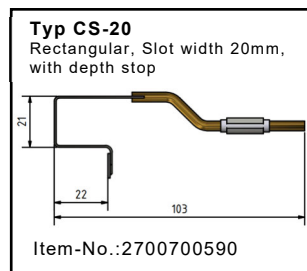
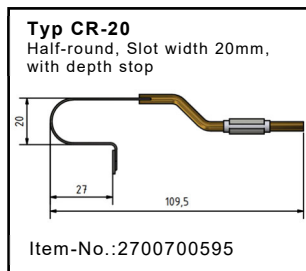

Accessories / Profile cut adapter

Item-No.: 7179090100

With the profile cutting adapter you can cut grooves from 20mm to 120mm wide in your material. The shape of the groove is freely configurable; to do this, you simply have to bring the cutting strip into the desired shape with a pair of pliers.

The stop plate of the adapter ensures a clean and angular cut.

The cutting band for the adapter can be ordered separately under article no. 7179080400.

The minimum length for the cutting band must be at least 100mm (A+B+C=min. 100mm) from the bottom of the adapter.

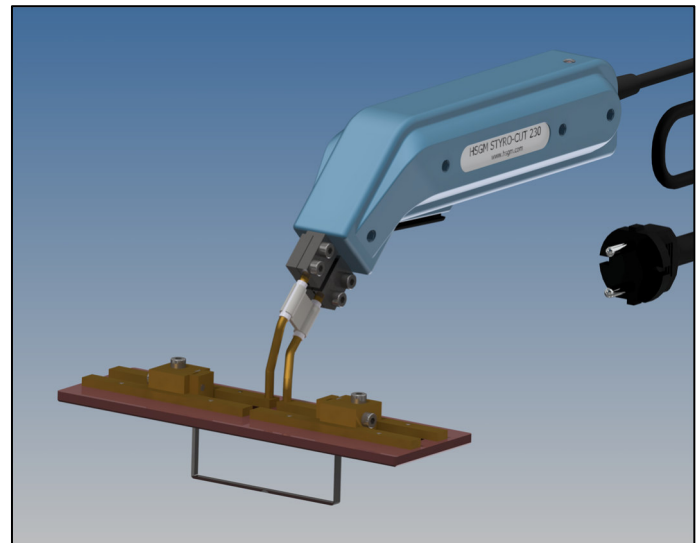
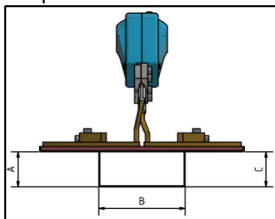

Profile cut adapter with HSGM-Styro-Cut-230
(HSGM-Styro-Cut 230 and cutting band not included in scope of delivery!)

Scope of delivery:

1x Profile cut adapter

HSGM-Styro-Cut 230 and cutting band not included in scope of delivery!